

INSTRUCTIONS: PMB-01-2203

**NOTE:** We recommend using a removable thread locking agent on all bolts.

1. **The installation of this rack requires drilling holes in your stock fender.** This is most easily accomplished with a 5/8" diameter hole saw. If you do not have a hole saw or do not feel comfortable drilling holes in your fender, have the rack installed by your dealer.
2. Remove stock tool bag from fender
3. Remove seat by using an 8mm wrench to remove two bolts near back of seat. Lift the back of the seat up and slide back to remove. **(FIGURE 1)**
4. Remove rear fender from the motorcycle by using an 8mm wrench to remove two bolts on the inside front corners of the fender. Gently pull the wire guide from fender by hand to completely separate the fender. **(FIGURE 2)**
5. Remove metal clip-on nuts from underside of fender with flat screwdriver. **(FIGURE 3)**



**FIGURE 1**

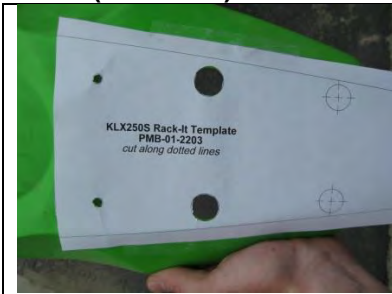

**FIGURE 2**



**FIGURE 3**

6. Cut out template on the dotted lines. Tape the template to the fender ensuring that the holes in the template line up with the holes in the fender. **(FIGURE 4)**
7. Using a small drill bit, drill two pilot holes through the center marks on template. **(FIGURE 5)**
8. Use the small holes just drilled in the fender as a guide for the 5/8" hole saw. Depending on the type of drill bit used, it may be necessary to separate the two halves of the fender by removing the five screws. **(FIGURE 6)**



**FIGURE 4**



**FIGURE 5**



**FIGURE 6**

9. Using an 8mm wrench, remove the tail light assembly. **(FIGURE 7)**
10. Remove the metal spacers from beneath the rubber grommets on the taillight assembly. Reinstall taillight assembly. **(FIGURE 8)**
11. Reinstall the seat; ensure both the front and center tabs are attached to the frame.
12. Install the rack spacers into the holes to verify alignment. The two shorter spacers should be placed in the front holes. Carefully trim the fender with a utility knife if necessary.
13. Loosely install the rack using the four supplied flat head bolts and nylock nuts. **(FIGURE 9)**



**FIGURE 7**



**FIGURE 8**



**FIGURE 9**

14. Tighten the four rack bolts.
15. The stock tool bag can be installed on the rack if desired. Pass the front rack mount bolts through the tool bag and thread two of the stock tool bag bolts into the tapped holes on the rack. **(FIGURE 10)**



**FIGURE 10**

### **Parts List:**

- 1-Top**
- 2-6x70 FH**
- 2-8x70 FH**
- 2-8x16x19 Spacers**
- 2-6x16x32 Spacers**
- 2-M6 Nylock Nuts**
- 2-M8 Nylock Nuts**

**CAUTION:** As with all racks on motorcycles, they should not have excess amounts of weight put on them. Excess weight can damage the rear sub-frame of the motorcycle.

See our entire product line at [promotobillet.com](http://promotobillet.com)

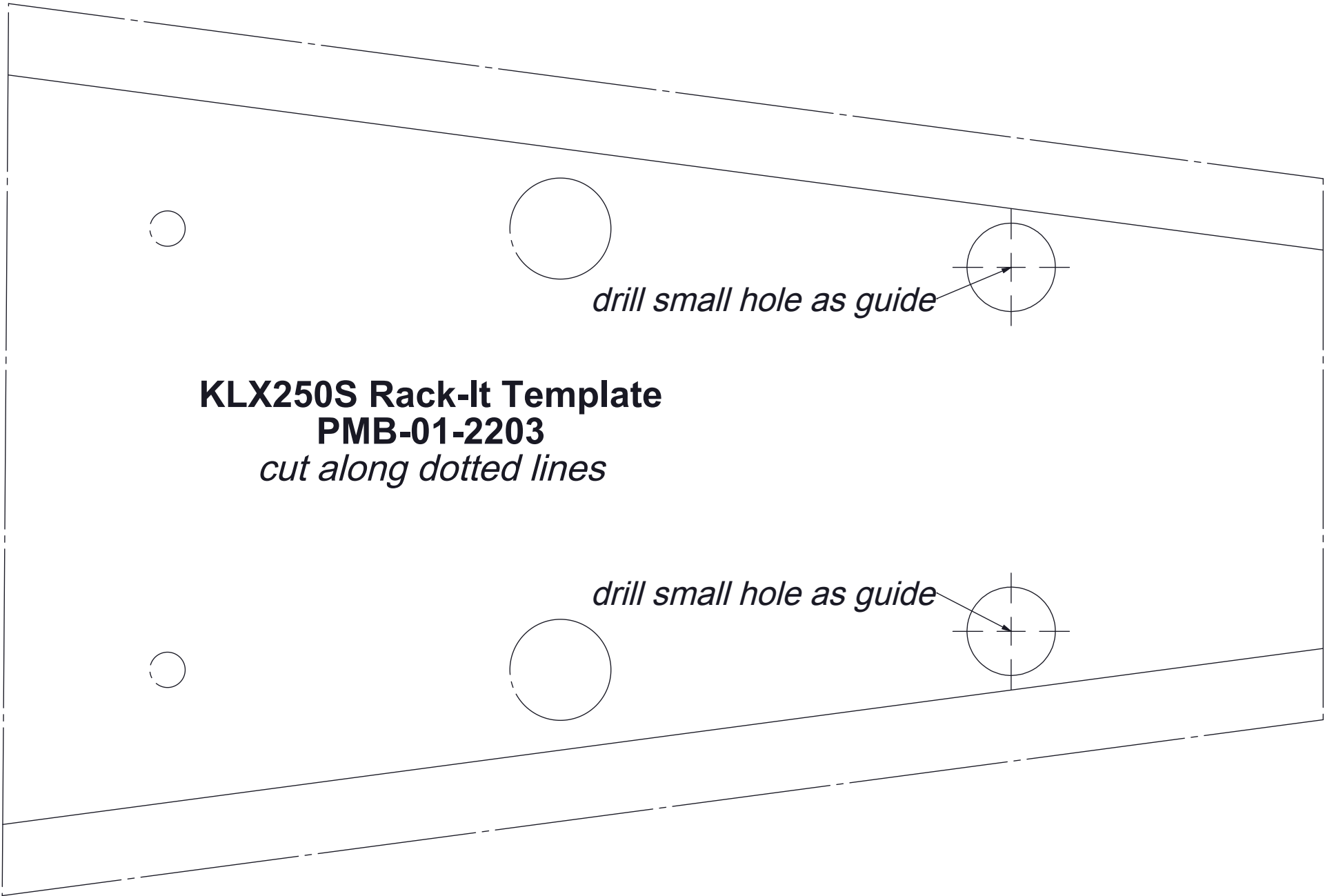

**KLX250S Rack-It Template**  
**PMB-01-2203**  
*cut along dotted lines*

*drill small hole as guide*

*drill small hole as guide*